

33.16 IDEA Top



- Asse "C" Asse angolare di rotazione a 360° in continuo.
- Achse "C" Achse winkeldrehung 360° kontinuierliche.
- Axe "C" axe de rotation angulaire de 360° en continu.
- Rotary axis "C" in continuous, to manage angular aggregates.
- Eje "C", eje de rotación angular de 360° continuamente.



- Aggregato con rinvio angolare a 90° per disco piatto ed incisione diam. 200 mm.
- Aggregate mit Kegelrad-triebe 90° für flache scheibe und gravieren, diam. 200 mm.
- Aggregate engrenage angulaire à 90° pour disque plat et la gravure, diam. 200 mm.
- Aggregate with a 90° angle gearbox for the use of the vertical cutting and engraving, disc diam. 200 mm.
- Transmisión mecánica angular de 90°, para disco plano y grabado de diam. 200 mm.



- L'ampia corsa in asse "Z" consente la lavorazione di materiali di grosso spessore.
- Die Große fahrt in der Z-Achse ermöglicht die Bearbeitung von dickeren Materialien.
- La grande course dans l'axe "Z" permet le travail de matériaux de grosse épaisseur.
- The large stroke in the "Z" axis allows the machining of high thickness materials.
- El movimiento amplio de la "Z" eje permite la elaboración de materiales de gran espesor.

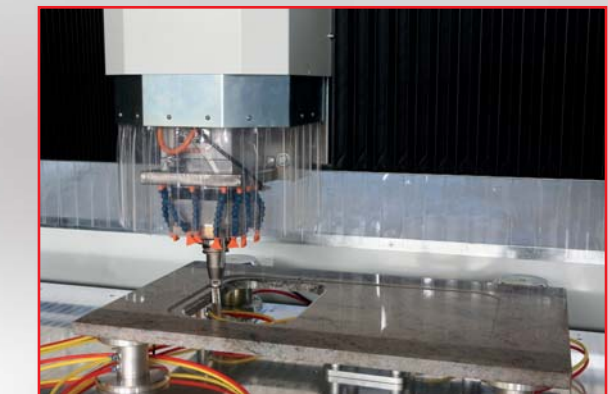
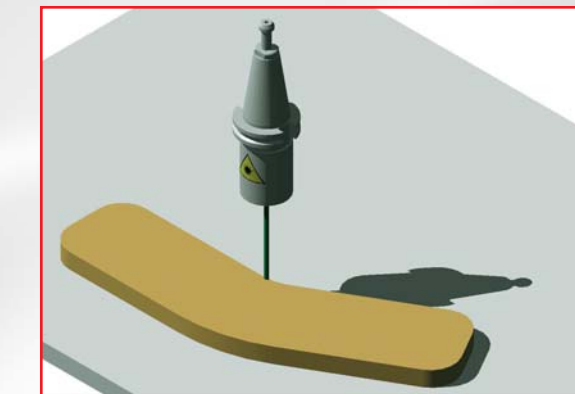

- Realizzazione di contornature e ribassi facilitata con l'uso di funzioni guidate dal programma.
- Einfache Bearbeitung von Konturen und Abtropfflächen durch bedienerfreundliche Programmierung.
- Réalisation de moulures et décaissés facilitée grâce à l'utilisation de fonctions guidées du programme.
- Profiling and recessing easy to create with dedicated programm functions.
- Realización de contorneados y rebajes facilitados con el uso de funciones guiadas por el programa.



- Copiatore di sagome con tecnologia laser.
- Vervielfältigung von Profilen mittels Lasertechnologie.
- Copieur de gabarit avec technologie laser.
- Laser template reader.
- Copiadore de formas con tecnología láser.

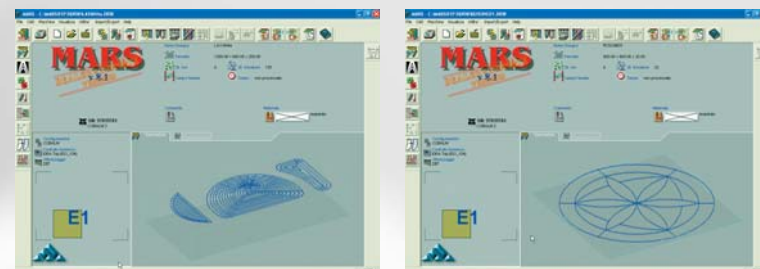

- Potente CAD/CAM con possibilità di programmazione artistica, geometrica o parametrica.
- Leistungsfähige CAD/CAM-Software mit gestaltungsfähiger Programmiermöglichkeit.
- Puissant CAD/CAM avec la possibilité d'une programmation artistique, géométrique ou paramétrique.
- Powerful CAD/CAM with artistic, geometrical and parametric programming.
- Potente CAD/CAM con posibilidad de programación artística, geometrica o parametrica.



- Teleassistenza: diagnostica remota della macchina e assistenza telefonica.
- Teleservice: Ferndiagnose für die Maschine und Telefon-Support.
- Téléservice: diagnostic à distance pour la machine et assistance téléphonique.
- Helpline: for remote diagnostic of the machine and telephone assistance.
- Teleasistencia: diagnostico remoto de la máquina y asistencia telefónica.

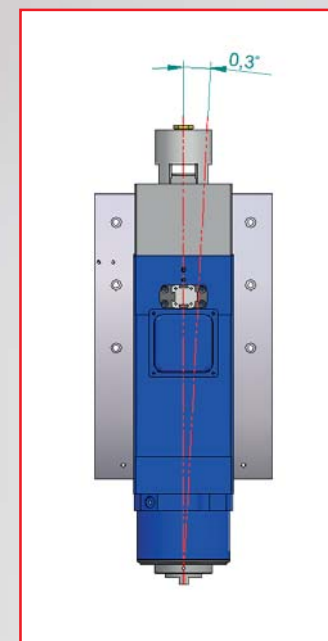

- Asse "T" Inclinazione manuale asse mandrino 0÷0,3 gradi.
- Achse "T" manual neigung der Spindelachse 0 bis 0,3 grad.
- Axe "T", basculement manuel de la broche 0 à 0,3 degrés.
- "T" axis manual tilting head 0÷0.3 degrees.
- Eje "T" la inclinación manual del eje de husillo de 0 a 0,3 grados.

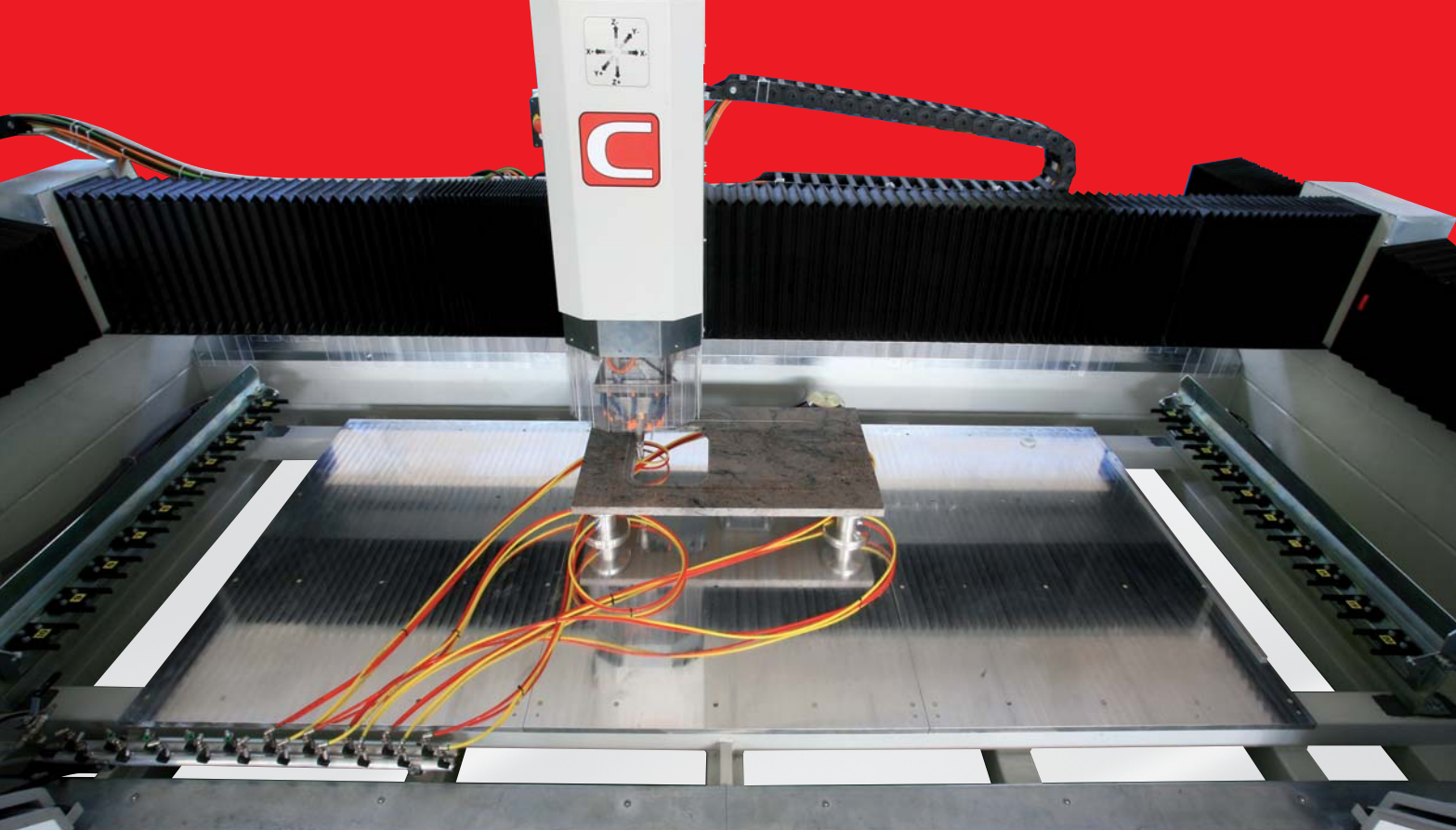

IDEA TOP 33.16

IDEA TOP 33.16

DATI TECNICI - TECHNISCHE DATEN - DONNES TECHNIQUES - TECHNICAL DATA - DATOS TÉCNICOS

MOD.							
	X, Y, Z	12+12	Ø max / L. max	RPM	kW	mm (L-P-H)	Kg
IDEA TOP 33.16	3200x1550x380	12+12 (4 axes 10+10)	125 / 200	0 / 10000	9 - ISO40	5650x2300x2300	3900

Centro di lavoro per fresatura, foratura, contornatura, ribassatura, scrittura, lucidatura e scolpitura.
 Gesteuertes Bearbeitungszentrum zum fräsen, bohren, konturbearbeiten, vertiefen, schreiben, polieren und modellieren.

Centre d'usinage pour fraisage, perçage, detourage, surbaissement, ecriture, polissage et sculpture.

Machining centre for milling, drilling, profiling, sinking, engraving, polishing and sculpting.

Centro de trabajo para fresado, perforación, perfilado, rebaje, escritura, pulido y esculpido.

- Ampio piano di lavoro in alluminio spessore 20 mm, pensato anche per facilitare il carico e lo scarico del materiale.
- Großzügig dimensionierter Arbeitstisch zum einfachen Auf- und Abbänken. Auch gedacht, um das be- und entladen des materials zu erleichtern.
- Grand plan machine pensé aussi pour faciliter les chargement e le déchargement du matériau à traiter.
- Wide working table; also thought to facilitate the loading and unloading of the material to be machined.
- Amplia mesa de máquina también pensado para facilitar la carga y descarga del material que se procesa.

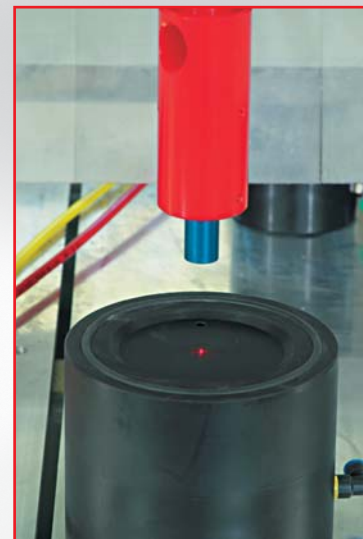

- Puntatore laser per facilitare il posizionamento di battute e ventose.
- Punktierlaser zum präzisen Positionieren der Anschläge und Vakuumsauger.
- Pointeur laser pour faciliter l'installation des butées et ventouses.
- Laser pointer for the vacuum cups positioning.
- Marcador láser para facilitar el emplazamiento de los topes y las ventosas.

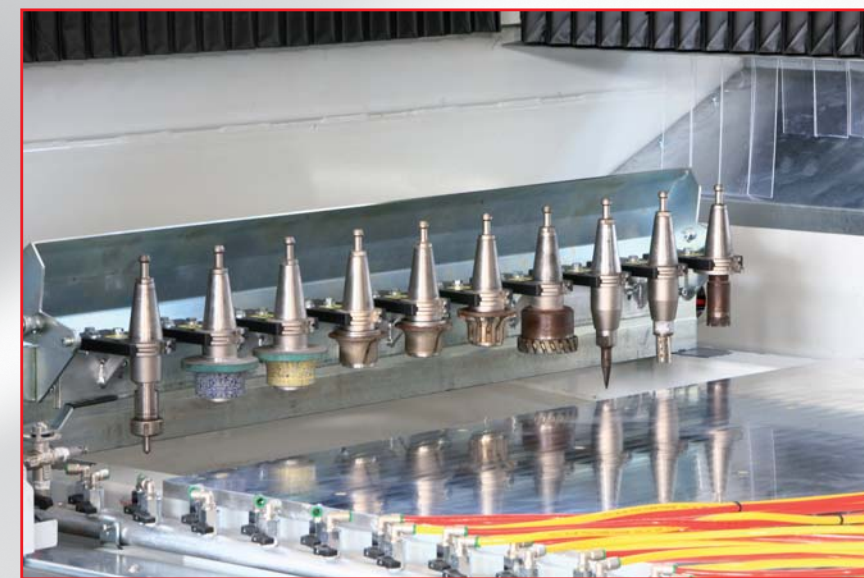

- Magazzino portautensili 12+12. (Macchina 4 assi 10+10).
- Werkzeug 12+12. (4-achs-Maschine 10+10).
- Magasin porte-outils 12+12. (Machine 4 axes 10+10).
- Tool magazine 12+12. (4 axis machine 10+10).
- Almacén portaherramientas 12+12. (Maquina de 4 eies 10+10).

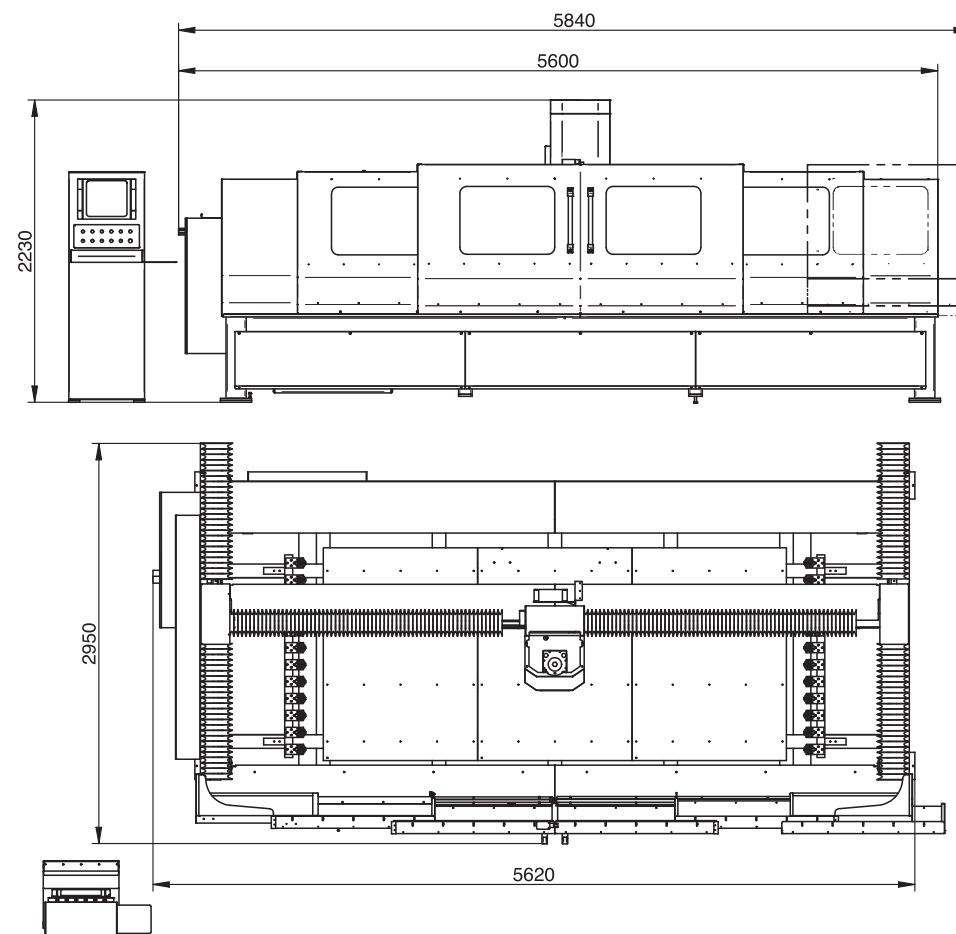

COBALM
STONE WORKING MACHINES

Via I. Silone, 3
 47039 Savignano sul Rubicone (FC) - ITALIA
 Tel. +39 0541 942228 - Fax +39 0541 942238
 www.cobalm.com - info@cobalm.com

La ditta COBALM si riserva di modificare a proprio giudizio i dati tecnici esposti a scopo di miglioramento senza darne preavviso. I dati indicati nel presente depliant sono da considerarsi puramente indicativi. We reserve the right to modify at our sole discretion the indicated technical data in order to improve. The data supplied in this catalogue must be considered for your reference only.



COBALM
STONE WORKING MACHINES